

Patent Pending

New features :

- "Second wedge design"
- Bolts incorporate a "Square Shank Base"

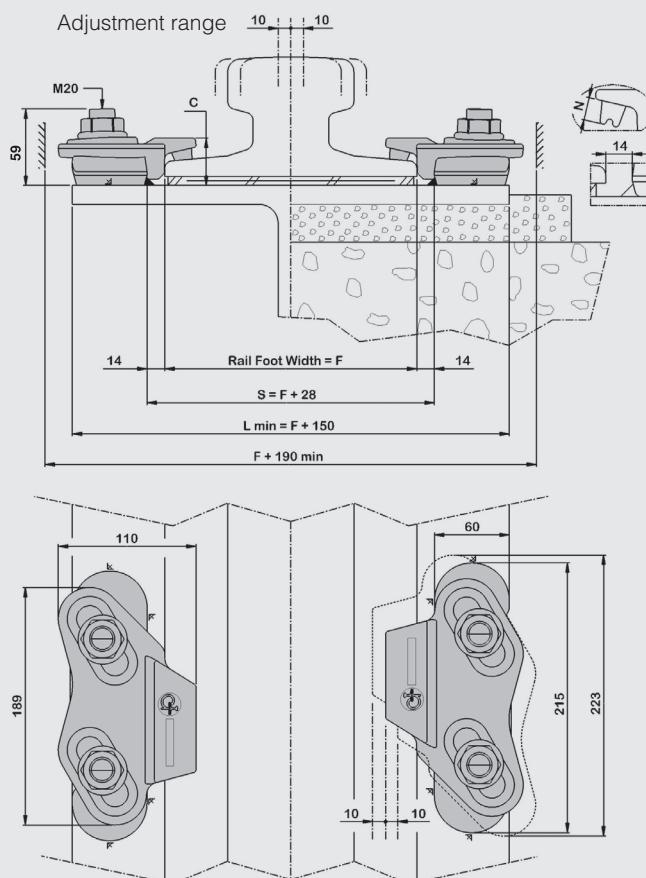

CLIPS	C max	Lateral adjustment	Bolt torque (Nm)	Maximum resistance to lateral forces (*)	Estimated weight
	mm	mm	Nm	kN	kg
W25/AN	33	20	350	235	2.600
W25/BN	38	20	350	235	2.620
W25/CN	46	20	350	235	2.690

N: nose height, not compressed, adapted to the rail type (see table overleaf).

(*) Contact GANTREX for application conditions.

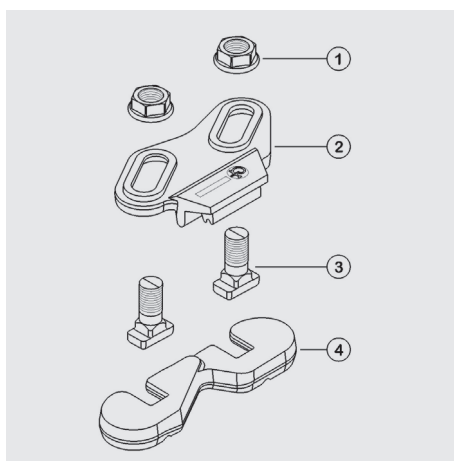

Full designation
W25/AN or W25/BN or W25/CN
Components
① 2x Sp M20 C18 GAL
② 1 x W25/30N or 1 x W25/33N or 1 x W25/41N
③ 2 x SSB M20x44.5 8.8 GAL
④ 1 x W25/26

Notes overleaf

- Clip Specification
- Clip Selection Table
Upper component and nose height (N) according to rail type and foot size (F).
- Components Materials
- Installation and Welding Instructions
Recommended weld throat size :
 6 mm; weld leg size being then 8.5 mm.
Any low hydrogen rod suitable for use with structural steel may be used.

CLIP SPECIFICATION

The RailLok™ patent pending clips are specifically designed to facilitate correct mounting of crane rails :

- The “**Second Wedge Design**” ensures tight contact with the rail foot.
- Bolts with “**Square Shank Base**” allow the use of impact-wrenches.
- Easier installation because of the wider adjustment range.
- Compact design : fits narrow girders and soleplates, avoid interference with guide rollers.

Once installed, the clips are self-locking and self-tightening.

CLIP SELECTION TABLE

	F mm	K mm	H mm	Weight kg/m	Mounting	
					with	without
					7 mm RailLok™ pad	
A100	200.0	100.0	95.0	74.30	W25/BJ	W25/AM
A120	220.0	120.0	105.0	100.00	W25/BI	W25/AJ
A150	220.0	150.0	150.0	150.30	W25/CM	W25/AI
CR73	140.0	100.0	135.0	73.30	W25/BH	W25/AI
CR100	155.0	120.0	150.0	100.20	W25/CJ	W25/BJ
MRS52 (105 CR)	131.8	65.1	131.8	52.09	W25/BJ	W25/AM
MRS85 (171 CR)	152.4	101.6	152.4	84.83	W25/CM	W25/AH
MRS87A	152.4	101.6	152.4	86.80	W25/CM	W25/AH
MRS87B (175CR)	152.4	102.4	152.4	86.80	W25/BH	W25/AJ
MRS125	180.0	120.0	180.0	125.00	W25/CH	W25/BH
QU80	130.0	80.0	130.0	63.70	W25/BJ	W25/AM
QU100	150.0	100.0	150.0	89.10	W25/BI	W25/AJ
QU120	170.0	120.0	170.0	118.10	W25/CM	W25/AI
UIC 60	225.0	72.0	172.0	60.34	W25/BJ	W25/AM

Contact GANTREX for other rails and pads.

COMPONENTS MATERIALS

The RailLok™ W25 is standard with a weldable forged steel lower component, a ductile cast iron upper component and vulcanize-bonded rubber nose. As standard, the bolts and nuts are hot dip galvanized. The upper component can also be hot dip galvanized on request.

Contact GANTREX for other options.

INSTALLATION AND SUGGESTED WELD INSTRUCTIONS

The lower component is welded on the support parallel to the axis of the rail and the upper component is fastened to it by means of the two bolts and nuts. The recommended torque is 350 Nm. Electrical and pneumatic torque wrenches are allowed as long as the minimum torque of 275 Nm is met and the torque does not exceed 500 Nm.

It is recommended the torque is regularly controlled with a calibrated torque wrench.

For most applications, the recommended weld throat size is \sqrt{K} - 6 mm; the weld leg size is then 8.5 mm. If the pad is not used, the weld along the foot of the rail must be removed. Use any low hydrogen rod suitable for use with structural steel: ISO2560 type E 42 5 B 32 H5, E7018 or equivalent. For full instructions on weld size and electrodes, refer to the data sheet "Installation and suggested weld instructions".

Do not apply protective coating on the contact surface between upper and lower components unless accepted by GANTREX. Do not use solvents as they may seriously damage the rubber nose.

We reserve the right to discontinue or change specifications or design at any time without prior notice and without incurring any obligation whatsoever.

08/2016 Rev.1